

B16.47 DIMENSION BOOK

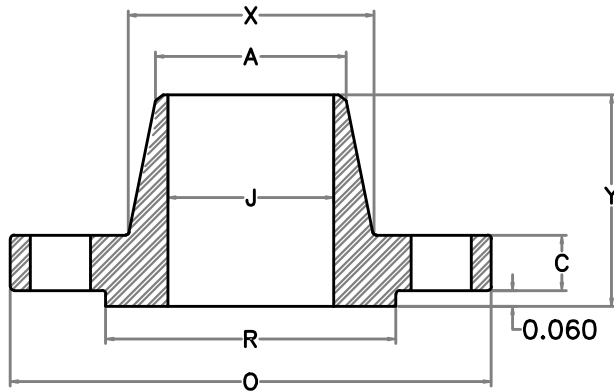

KERKAU MANUFACTURING



WELDING NECK

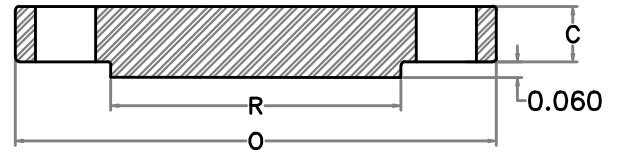

BLIND

ANSI B16.47 SERIES A CLASS 150 FLANGE DIMENSIONS

Nominal Pipe Size	O.D. of Flange O	Minimum Thickness of flange		Legnth Through Hub Y	Dimension of Hub X	Hub Diameter at Weld End A	Raised Face Dimension R	Drilling			Diameter of Bolts	Minimum Fillet Radius r
		Weld Neck	Blind					Diameter of Bolt Circle	Number of Bolt Holes	Diameter of Bolt Holes		
26	34.25	2.630	2.630	4.69	26.62	26.00	29.50	31.75	24	1.375	1 1/4	0.380
28	36.50	2.750	2.750	4.88	28.62	28.00	31.50	34.00	28	1.375	1 1/4	0.440
30	38.75	2.880	2.880	5.32	30.75	30.00	33.75	36.00	28	1.375	1 1/4	0.440
32	41.75	3.130	3.130	5.63	32.75	32.00	36.00	38.50	28	1.625	1 1/2	0.440
34	43.75	3.190	3.190	5.82	34.75	34.00	38.00	40.50	32	1.625	1 1/2	0.500
36	46.00	3.500	3.500	6.13	63.75	36.00	40.25	42.75	32	1.625	1 1/2	0.500
38	48.75	3.380	3.380	6.13	39.00	38.00	42.25	45.25	32	1.625	1 1/2	0.500
40	50.75	3.500	3.500	6.38	41.00	40.00	44.25	47.25	36	1.625	1 1/2	0.500
42	53.00	3.750	3.750	6.69	43.00	42.00	47.00	49.50	36	1.625	1 1/2	0.500
44	55.25	3.940	3.940	6.94	45.00	44.00	49.00	51.75	40	1.625	1 1/2	0.500
46	57.25	4.000	4.000	7.25	47.12	46.00	51.00	53.75	40	1.625	1 1/2	0.500
48	59.50	4.190	4.190	7.50	49.12	48.00	53.50	56.00	44	1.625	1 1/2	0.500
50	61.75	4.320	4.320	7.94	51.25	50.00	55.50	58.25	44	1.875	1 3/4	0.500
52	64.00	4.500	4.500	8.19	53.25	52.00	57.50	60.50	44	1.875	1 3/4	0.500
54	66.25	4.690	4.690	8.44	55.25	54.00	59.50	62.75	44	1.875	1 3/4	0.500
56	68.75	4.820	4.820	8.94	57.38	56.00	62.00	65.00	48	1.875	1 3/4	0.500
58	71.00	5.000	5.000	9.19	59.38	58.00	64.00	67.25	48	1.875	1 3/4	0.500
60	73.00	5.130	5.130	9.38	61.38	60.00	66.00	69.25	52	1.875	1 3/4	0.500

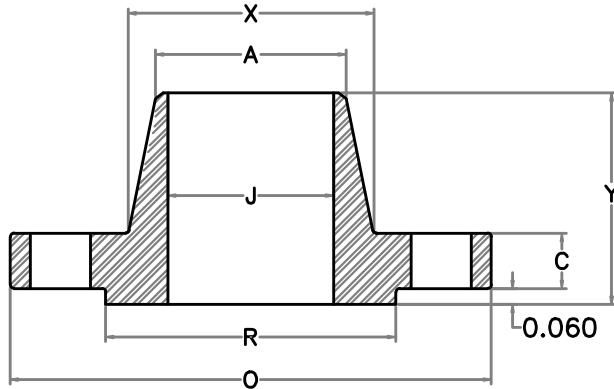

WELDING NECK

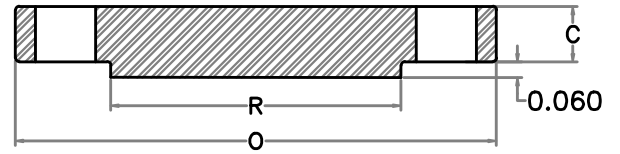

BLIND

ANSI B16.47 SERIES A CLASS 300 FLANGE DIMENSIONS

Nominal Pipe Size	O.D. of Flange O	Minimum Thickness of flange		Legnth Through Hub Y	Dimension of Hub X	Hub Diameter at Weld End A	Raised Face Dimension R	Drilling			Diameter of Bolts	Minimum Fillet Radius r
		Weld Neck	Blind					Diameter of Bolt Circle	Number of Bolt Holes	Diameter of Bolt Holes		
26	38.25	3.07	3.25	7.19	28.38	26.00	29.50	34.50	28	1.750	1 5/8	0.380
28	40.75	3.32	3.50	7.69	30.50	28.00	31.50	37.00	28	1.750	1 5/8	0.440
30	43.00	3.57	3.69	8.19	32.56	30.00	33.75	39.25	28	1.875	1 3/4	0.440
32	45.25	3.82	3.88	8.69	34.69	32.00	36.00	41.50	28	2.000	1 7/8	0.440
34	47.50	3.94	4.07	9.07	36.88	34.00	38.00	43.50	28	2.000	1 7/8	0.500
36	50.00	4.07	4.32	9.44	39.00	36.00	40.25	46.00	32	2.125	2	0.500
38	46.00	4.19	4.19	7.06	39.12	38.00	40.50	43.00	32	1.625	1 1/2	0.500
40	48.75	4.44	4.44	7.56	41.25	40.00	42.75	45.50	32	1.750	1 5/8	0.500
42	50.75	4.63	4.63	7.82	43.25	42.00	44.75	47.50	32	1.750	1 5/8	0.500
44	53.25	4.82	4.82	8.06	45.25	44.00	47.00	49.75	32	1.875	1 3/4	0.500
46	55.75	5.00	5.00	8.44	47.38	46.00	49.00	52.00	28	2.000	1 7/8	0.500
48	57.75	5.19	5.19	8.75	49.38	48.00	51.25	54.00	32	2.000	1 7/8	0.500
50	60.25	5.44	5.44	9.07	51.38	50.00	53.50	56.25	32	2.125	2	0.500
52	62.25	5.63	5.63	9.32	53.38	52.00	55.50	58.25	32	2.125	2	0.500
54	65.25	6.94	6.94	9.88	55.50	54.00	57.75	61.00	28	2.375	2 1/4	0.500
56	67.25	6.00	6.00	10.19	57.62	56.00	59.75	63.00	28	2.375	2 1/4	0.500
58	69.25	6.19	6.19	10.44	59.62	58.00	62.00	65.00	32	2.375	2 1/4	0.500
60	71.25	6.38	6.38	10.69	61.62	60.00	64.00	67.00	32	2.375	2 1/4	0.500

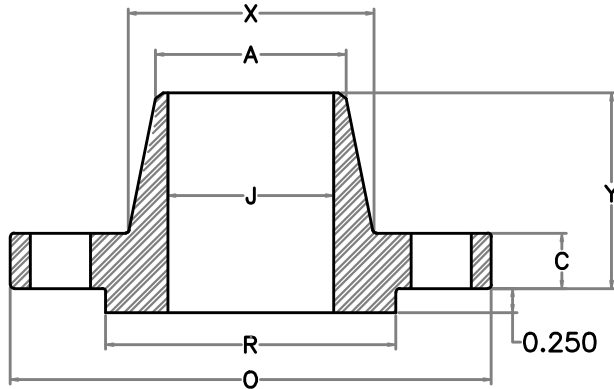

WELDING NECK

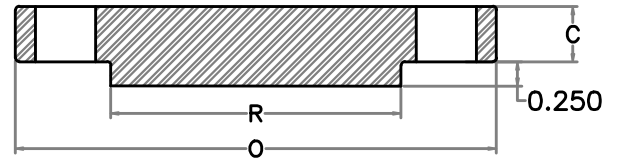

BLIND

ANSI B16.47 SERIES A CLASS 400 FLANGE DIMENSIONS

Nominal Pipe Size	O.D. of Flange O	Minimum Thickness of flange		Legnth Through Hub Y	Dimension of Hub X	Hub Diameter at Weld End A	Raised Face Dimension R	Drilling			Diameter of Bolts	Minimum Fillet Radius r
		Weld Neck	Blind					Diameter of Bolt Circle	Number of Bolt Holes	Diameter of Bolt Holes		
26	38.25	3.50	3.88	7.62	28.62	26.00	29.50	34.50	28	1.875	1 3/4	0.440
28	40.75	3.75	4.12	8.12	30.81	28.00	31.50	37.00	28	2.000	1 7/8	0.500
30	43.00	4.00	4.38	8.62	32.94	30.00	33.75	39.25	28	2.125	2	0.500
32	45.25	4.25	4.56	9.12	35.00	32.00	36.00	41.50	28	2.125	2	0.500
34	47.50	4.38	4.81	9.50	37.19	34.00	38.00	43.50	28	2.125	2	0.560
36	50.00	4.50	5.06	9.88	39.38	36.00	40.25	46.00	32	1.875	2	0.560
38	47.50	4.88	4.88	8.12	39.50	38.00	40.75	44.00	32	2.000	1 3/4	0.560
40	50.00	5.12	5.12	8.50	41.50	40.00	43.00	46.25	32	2.000	1 7/8	0.560
42	52.00	5.25	5.25	8.81	43.62	42.00	45.00	48.25	32	2.125	1 7/8	0.560
44	54.50	5.50	5.50	9.18	45.62	44.00	47.25	50.50	32	2.125	2	0.560
46	56.75	5.75	5.75	9.62	47.75	46.00	49.50	52.75	36	2.375	2	0.560
48	59.50	6.00	6.00	10.12	49.88	48.00	51.50	55.25	28	2.375	2 1/4	0.560
50	61.75	6.19	6.25	10.56	52.00	50.00	53.62	57.50	32	2.375	2 1/4	0.560
52	63.75	6.38	6.44	10.88	54.00	52.00	55.62	59.50	32	2.375	2 1/4	0.560
54	67.00	6.69	6.75	11.38	56.12	54.00	57.88	62.25	28	2.625	2 1/2	0.560
56	69.00	3.88	6.94	11.75	58.25	56.00	60.12	64.25	32	2.625	2 1/2	0.560
58	71.00	7.00	7.12	12.06	60.25	58.00	62.12	66.25	32	2.625	2 1/2	0.560
60	74.25	7.44	7.44	12.56	62.38	60.00	64.38	69.00	32	2.875	2 3/4	0.560

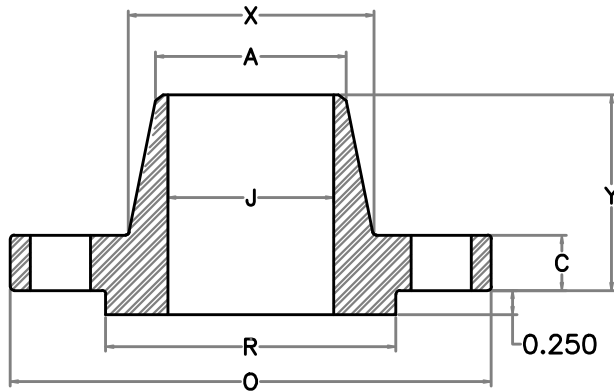

WELDING NECK

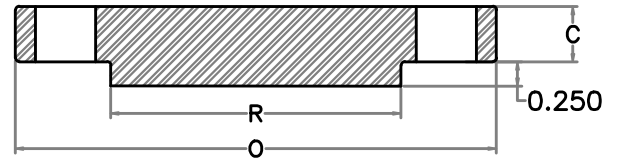

BLIND

ANSI B16.47 SERIES A CLASS 600 FLANGE DIMENSIONS

Nominal Pipe Size	O.D. of Flange O	Minimum Thickness of flange		Legnth Through Hub Y	Dimension of Hub X	Hub Diameter at Weld End A	Raised Face Dimension R	Drilling			Diameter of Bolts	Minimum Fillet Radius r
		Weld Neck	Blind					Diameter of Bolt Circle	Number of Bolt Holes	Diameter of Bolt Holes		
26	40.00	4.25	4.94	8.75	29.44	26.00	29.50	36.00	28	2.000	1 7/8	0.500
28	42.25	4.38	5.19	9.25	31.62	28.00	31.50	38.00	28	2.125	2	0.500
30	44.50	4.50	5.50	9.75	33.94	30.00	33.75	40.25	28	2.125	2	0.500
32	47.00	4.62	5.81	10.25	36.12	32.00	36.00	42.50	28	2.375	2 1/4	0.500
34	49.00	4.75	6.06	10.62	38.31	34.00	38.00	44.50	28	2.375	2 1/4	0.560
36	51.75	4.88	6.38	11.12	40.62	36.00	40.25	47.00	28	2.625	2 1/2	0.560
38	50.00	6.00	6.12	10.00	40.25	38.00	41.50	45.75	28	2.375	2 1/4	0.560
40	52.00	6.25	6.38	10.38	42.25	40.00	43.75	47.75	32	2.375	2 1/4	0.560
42	55.25	6.62	6.75	11.00	44.38	42.00	46.00	50.50	28	2.625	2 1/2	0.560
44	57.25	6.81	7.00	11.38	46.50	44.00	48.25	52.50	32	2.625	2 1/2	0.560
46	59.50	7.06	7.31	11.81	48.62	46.00	50.25	54.75	32	2.625	2 1/2	0.560
48	62.75	7.44	7.69	12.44	50.75	48.00	52.50	57.50	32	2.875	2 3/4	0.560
50	65.75	7.75	8.00	12.94	52.88	50.00	54.50	60.00	28	3.125	3	0.560
52	67.75	8.00	8.25	13.25	54.88	52.00	56.50	62.00	32	3.125	3	0.560
54	70.00	8.25	8.56	13.75	57.00	54.00	58.75	64.25	32	3.125	3	0.560
56	73.00	8.56	8.88	14.25	59.12	56.00	60.75	66.75	32	3.375	3 1/4	0.620
58	75.00	8.75	9.12	14.56	61.12	58.00	63.00	68.75	32	3.375	3 1/4	0.620
60	78.50	9.19	9.56	15.31	63.38	60.00	65.25	71.75	28	3.625	3 1/2	0.690

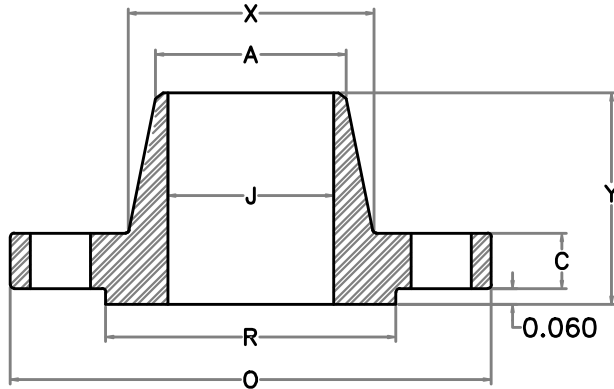

WELDING NECK

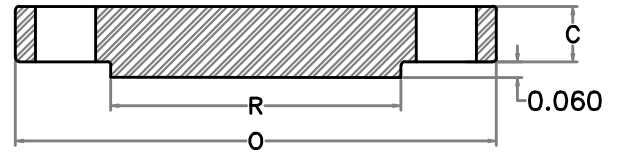

BLIND

ANSI B16.47 SERIES B CLASS 75 FLANGE DIMENSIONS

Nominal Pipe Size	O.D. of Flange O	Minimum Thickness of flange		Legnth Through Hub Y	Dimension of Hub X	Hub Diameter at Weld End A	Raised Face Dimension R	Drilling			Diameter of Bolts	Minimum Fillet Radius r
		Weld Neck	Blind					Diameter of Bolt Circle	Number of Bolt Holes	Diameter of Bolt Holes		
26	30.00	1.25	1.25	2.25	26.62	26.06	27.75	28.50	36	0.750	5/8	0.310
28	32.00	1.25	1.25	2.38	28.62	28.06	29.75	30.50	40	0.750	5/8	0.310
30	34.00	1.25	1.25	2.50	30.62	30.06	31.75	32.50	44	0.750	5/8	0.310
32	36.00	1.32	1.38	2.69	32.62	32.06	33.75	34.50	48	0.75	5/8	0.310
34	38.00	1.32	1.44	2.82	34.62	34.06	35.75	36.50	52	0.75	5/8	0.310
36	40.69	1.38	1.61	3.32	36.81	36.06	38.00	39.06	40	0.875	3/4	0.380
38	42.69	1.44	1.69	3.44	38.81	38.06	40.00	41.06	40	0.875	3/4	0.380
40	44.69	1.44	1.69	3.57	40.81	40.06	42.00	43.06	44	0.875	3/4	0.380
42	46.69	1.50	1.82	3.69	42.81	42.06	44.00	45.06	48	0.875	3/4	0.380
44	49.25	1.63	1.88	4.07	44.88	44.06	46.25	47.38	36	1.000	7/8	0.380
46	51.25	1.69	1.94	4.19	46.88	46.06	48.25	49.38	40	1.000	7/8	0.380
48	53.25	1.75	2.07	4.32	48.88	48.06	50.25	51.38	44	1.000	7/8	0.380
50	55.25	1.82	2.13	4.50	50.94	50.06	52.25	53.38	44	1.000	7/8	0.380
52	57.38	1.82	2.19	4.69	52.94	52.06	54.25	55.50	48	1.000	7/8	0.380
54	59.38	1.88	2.32	4.88	55.00	54.06	56.25	57.50	48	1.000	7/8	0.380
56	62.00	1.94	2.38	5.25	57.12	56.06	58.50	59.88	40	1.125	1	0.440
58	64.00	2.00	2.44	5.38	59.12	58.06	60.50	61.88	44	1.125	1	0.440
60	66.00	2.13	2.57	5.63	61.12	60.06	62.50	63.88	44	1.125	1	0.440

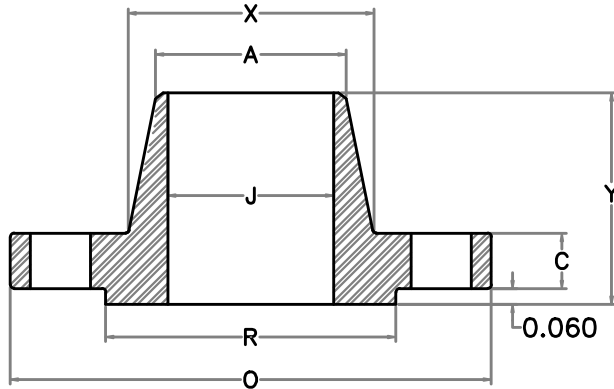

WELDING NECK

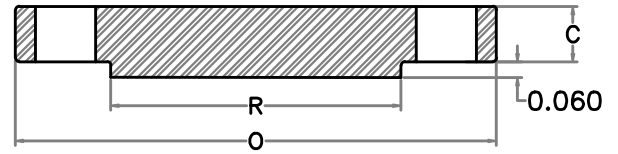

BLIND

ANSI B16.47 SERIES B CLASS 150 FLANGE DIMENSIONS

Nominal Pipe Size	O.D. of Flange O	Minimum Thickness of flange		Legnth Through Hub Y	Dimension of Hub X	Hub Diameter at Weld End A	Raised Face Dimension R	Drilling			Diameter of Bolts	Minimum Fillet Radius r
		Weld Neck	Blind					Diameter of Bolt Circle	Number of Bolt Holes	Diameter of Bolt Holes		
26	30.94	1.57	1.69	3.44	26.94	26.06	28.00	39.36	36	0.875	3/4	0.380
28	32.94	1.69	1.82	3.69	28.94	28.06	30.00	31.31	40	0.875	3/4	0.380
30	34.94	1.69	1.94	3.88	31.00	30.06	32.00	33.31	44	0.875	3/4	0.380
32	37.06	1.75	2.07	4.19	33.06	32.06	34.00	35.44	48	0.875	3/4	0.380
34	39.56	1.88	2.19	4.28	35.12	34.06	36.25	37.69	40	1	7/8	0.380
36	41.62	2.00	2.25	4.57	37.19	36.06	38.25	39.75	44	1	7/8	0.380
38	44.25	2.07	2.44	4.82	39.25	38.12	40.25	42.12	40	1.125	1	0.380
40	46.25	2.13	2.57	5.00	41.31	40.12	42.50	44.12	44	1.125	1	0.380
42	48.25	2.25	2.63	5.19	43.38	42.12	44.50	46.12	48	1.125	1	0.440
44	50.25	2.32	2.75	5.32	45.38	44.12	46.50	48.12	52	1.125	1	0.440
46	52.81	2.38	2.88	5.63	47.44	46.12	48.62	50.56	40	1.250	1 1/8	0.440
48	54.81	2.50	3.00	5.82	49.50	48.12	50.75	52.56	44	1.250	1 1/8	0.440
50	56.81	2.63	3.13	6.00	51.50	50.12	52.75	54.56	48	1.250	1 1/8	0.440
52	58.81	2.69	3.25	6.13	53.56	52.12	54.75	56.56	52	1.250	1 1/8	0.440
54	61.00	2.75	3.38	6.32	55.62	54.12	56.75	58.75	56	1.250	1 1/8	0.440
56	63.00	2.82	3.50	6.50	57.69	56.12	58.75	60.75	60	1.25	1 1/8	0.560
58	65.94	2.88	3.62	6.82	59.69	58.12	60.75	63.44	48	1.375	1 1/4	0.560
60	67.94	2.94	3.75	7.00	61.81	60.12	63.00	65.44	52	1.375	1 1/4	0.560

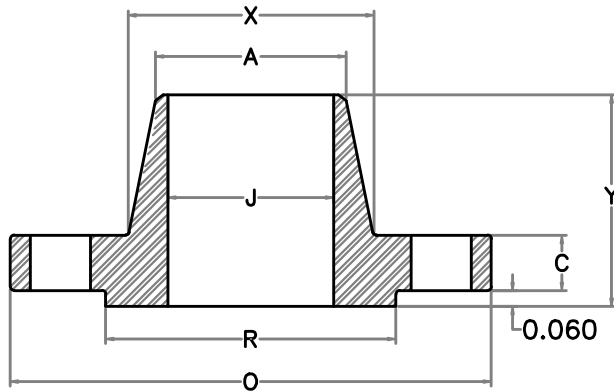

WELDING NECK

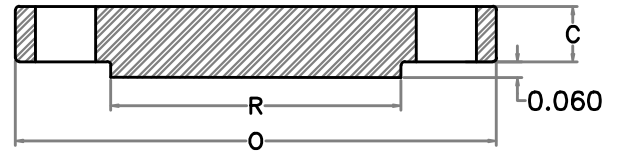

BLIND

ANSI B16.47 SERIES B CLASS 300 FLANGE DIMENSIONS

Nominal Pipe Size	O.D. of Flange O	Minimum Thickness of flange		Legnth Through Hub Y	Dimension of Hub X	Hub Diameter at Weld End A	Raised Face Dimension R	Drilling			Diameter of Bolts	Minimum Fillet Radius r
		Weld Neck	Blind					Diameter of Bolt Circle	Number of Bolt Holes	Diameter of Bolt Holes		
26	34.12	3.44	3.44	5.63	27.62	26.19	29.00	31.62	32	1.375	1 1/4	0.560
28	36.25	3.44	3.44	5.81	29.75	28.19	31.00	33.75	36	1.375	1 1/4	0.560
30	39.00	3.63	3.63	6.16	32.00	30.25	33.25	36.25	36	1.500	1 3/8	0.560
32	41.50	4.00	4.00	6.56	34.00	32.25	35.50	38.50	32	1.625	1 1/2	0.620
34	43.62	4.00	4.00	6.75	36.12	34.25	37.50	40.62	36	1.625	1 1/2	0.620
36	46.12	4.00	4.00	7.06	38.00	36.25	39.75	42.88	32	1.750	1 5/8	0.620
38	48.12	4.31	4.31	7.50	40.00	38.25	41.75	44.88	36	1.750	1 5/8	0.620
40	50.12	4.50	4.50	7.75	42.00	40.25	43.88	46.88	40	1.750	1 5/8	0.620
42	52.50	4.63	4.63	8.00	44.00	42.31	46.00	49.00	36	1.875	1 3/4	0.620
44	54.50	4.94	4.94	8.38	46.19	44.31	48.00	51.00	40	1.875	1 3/4	0.620
46	57.50	5.00	5.06	8.69	48.38	46.31	50.00	53.75	36	2.000	1 7/8	0.620
48	59.50	5.00	5.25	8.75	50.31	48.31	52.25	55.75	40	2.000	1 7/8	0.620
50	61.50	5.38	5.44	9.19	52.38	50.31	54.25	57.75	44	2.000	1 7/8	0.620
52	63.50	5.56	5.61	9.50	54.44	52.31	56.25	59.75	48	2.000	1 7/8	0.620
54	65.88	5.32	5.81	9.38	56.50	54.31	58.25	62.12	48	2.000	1 7/8	0.620
56	69.50	6.00	3.12	10.50	58.81	56.31	60.50	65.00	36	2.375	2 1/4	0.690
58	71.94	6.00	6.31	10.75	60.94	58.31	62.75	67.44	40	2.375	2 1/4	0.690
60	73.94	5.88	6.50	10.63	62.94	60.31	65.00	69.44	10	2.375	2 1/4	0.690



FLANGE TOLERANCES

GENERAL NOTE: Dimensions are in inches.

*Outside Diameter of Flange (dimension O)

±0.200

Thickness of Flange (dimension C)

C ≤ 1 in.	+0.12, -0.00
1 in. < C ≤ 2 in.	+0.19, -0.00
2 in. < C ≤ 3 in.	+0.31, -0.00
C > 3 in.	+0.38, -0.00

Hub

*Diameter of hub at base (dimension X)
NPS 6 and larger ±0.060

Taper of hub
≤ 7°

Outside diameter of welding end of welding neck flanges (dimension A)
+0.21, -0.06

Wall thickness (welding neck flanges)
min. 87.5% of the nominal

Length Through Hub (dimension Y)

Welding Neck
NPS 12 and larger ±0.19

Bore

Welding Neck (dimension J)
NPS 20 and larger +0.120, -0.060

Facings

*Facing Height
±0.010

Diameter of raised face (dimension R & K)

0.06 in. raised face ±0.080

0.25 in. raised face ±0.040

Ring Type Joint +0.020, -zero

Ring Joint Facing

Depth (dimension E)
+0.016, -zero

Width (dimension F)
±0.008

Pitch diameter (dimension P)
±0.005

Radius at bottom (dimension R)
R ≤ 0.060 +0.030, -zero
R > 0.060 ±0.030

23 degree angle
±½ deg.

Drilling

Diameter of bolt circle
±0.060

Center-to-center of adjacent bolt holes
±0.030

Eccentricity between bolt circle and diameter and machined facing diameters
NPS 3 and larger ±0.060

*Diameter of bolt holes
±0.020

Note: Tolerances marked with an * are Kerkau Tolerances

BORE SCHEDULES



ASME B36.10M - 1996

NOMINAL WALL THICKNESS AND INSIDE DIAMETER														
Nominal Pipe Size	Outside Diameter	wall thickness	Bore size	schedule	Nominal Pipe Size	Outside Diameter	wall thickness	Bore size	schedule	Nominal Pipe Size	Outside Diameter	wall thickness	Bore size	schedule
26	26.000	0.25	25.500		28	28.000	0.25	27.500	5	30	30.000	0.25	29.500	5
	26.000	0.281	25.438			28.000	0.281	27.438			30.000	0.281	29.438	
	26.000	0.312	25.376	10		28.000	0.312	27.376	10		30.000	0.312	29.376	10
	26.000	0.344	25.312			28.000	0.344	27.312			30.000	0.344	29.312	
	26.000	0.375	25.250	STD		28.000	0.375	27.250	STD		30.000	0.375	29.250	STD
	26.000	0.406	25.188			28.000	0.406	27.188			30.000	0.406	29.188	
	26.000	0.438	25.124			28.000	0.438	27.124			30.000	0.438	29.124	
	26.000	0.469	25.062			28.000	0.469	27.062			30.000	0.469	29.062	
	26.000	0.5	25.000	XH/20		28.000	0.5	27.000	XH/20		30.000	0.5	29.000	XH/20
	26.000	0.562	24.876			28.000	0.562	26.876			30.000	0.562	28.876	
	26.000	0.625	24.750	30		28.000	0.625	26.750	30		30.000	0.625	28.750	30
	26.000	0.688	24.624			28.000	0.688	26.624			30.000	0.688	28.624	
	26.000	0.75	24.500			28.000	0.75	26.500			30.000	0.75	28.500	
	26.000	0.812	24.376			28.000	0.812	26.376			30.000	0.812	28.376	
	26.000	0.875	24.250			28.000	0.875	26.250			30.000	0.875	28.250	
	26.000	0.938	24.124			28.000	0.938	26.124			30.000	0.938	28.124	
	26.000	1	24.000			28.000	1	26.000			30.000	1	28.000	
											30.000	1.062	27.876	
											30.000	1.125	27.750	
											30.000	1.188	27.624	
											30.000	1.25	27.500	

Note: Dimensions are in inches.

Note: Bore schedules with wall thickness greater than .88 are in bold print, indicating different welding end contour.

BORE SCHEDULES



ASME B36.10M - 1996

NOMINAL WALL THICKNESS AND INSIDE DIAMETER														
Nominal Pipe Size	Outside Diameter	wall thickness	Bore size	schedule	Nominal Pipe Size	Outside Diameter	wall thickness	Bore size	schedule	Nominal Pipe Size	Outside Diameter	wall thickness	Bore size	schedule
32	32.000	0.25	31.500		34	34.000	0.25	33.500		36	36.000	0.25	35.500	
	32.000	0.281	31.438			34.000	0.281	33.438			36.000	0.281	35.438	
	32.000	0.312	31.376	10		34.000	0.312	33.376	10		36.000	0.312	35.376	10
	32.000	0.344	31.312			34.000	0.344	33.312			36.000	0.344	35.312	
	32.000	0.375	31.250	STD		34.000	0.375	33.250	STD		36.000	0.375	35.250	STD
	32.000	0.406	31.188			34.000	0.406	33.188			36.000	0.406	35.188	
	32.000	0.438	31.124			34.000	0.438	33.124			36.000	0.438	35.124	
	32.000	0.469	31.062			34.000	0.469	33.062			36.000	0.469	35.062	
	32.000	0.5	31.000	XH/20		34.000	0.5	33.000	XH/20		36.000	0.5	35.000	XH/20
	32.000	0.562	30.876			34.000	0.562	32.876			36.000	0.562	34.876	
	32.000	0.625	30.750	30		34.000	0.625	32.750	30		36.000	0.625	34.750	30
	32.000	0.688	30.624	40		34.000	0.688	32.624	40		36.000	0.688	34.624	
	32.000	0.75	30.500			34.000	0.75	32.500			36.000	0.75	34.500	40
	32.000	0.812	30.376			34.000	0.812	32.376			36.000	0.812	34.376	
	32.000	0.875	30.250			34.000	0.875	32.250			36.000	0.875	34.250	
	32.000	0.938	30.124			34.000	0.938	32.124			36.000	0.938	34.124	
	32.000	1	30.000			34.000	1	32.000			36.000	1	34.000	
	32.000	1.062	29.876			34.000	1.062	31.876			36.000	1.062	33.876	
	32.000	1.125	29.750			34.000	1.125	31.750			36.000	1.125	33.750	
	32.000	1.188	29.624			34.000	1.188	31.624			36.000	1.188	33.624	
	32.000	1.25	29.500			34.000	1.25	31.500			36.000	1.25	33.500	

Note: Dimensions are in inches.

Note: Bore schedules with wall thickness greater than .88 are in bold print, indicating different welding end contour.

BORE SCHEDULES



ASME B36.10M - 1996

NOMINAL WALL THICKNESS AND INSIDE DIAMETER														
Nominal Pipe Size	Outside Diameter	wall thickness	Bore size	schedule	Nominal Pipe Size	Outside Diameter	wall thickness	Bore size	schedule	Nominal Pipe Size	Outside Diameter	wall thickness	Bore size	schedule
38	38.000	0.25	37.500		40	40.000	0.25	39.500		42	42.000	0.25	41.500	
	38.000	0.281	37.438			40.000	0.281	39.438			42.000	0.281	41.438	
	38.000	0.312	37.376			40.000	0.312	39.376			42.000	0.312	41.376	
	38.000	0.344	37.312			40.000	0.344	39.312			42.000	0.344	41.312	
	38.000	0.375	37.250	STD		40.000	0.375	39.250	STD		42.000	0.375	41.250	STD
	38.000	0.406	37.188			40.000	0.406	39.188			42.000	0.406	41.188	
	38.000	0.438	37.124			40.000	0.438	39.124			42.000	0.438	41.124	
	38.000	0.469	37.062			40.000	0.469	39.062			42.000	0.469	41.062	
	38.000	0.5	37.000	XH		40.000	0.5	39.000	XH		42.000	0.5	41.000	XH
	38.000	0.562	36.876			40.000	0.562	38.876			42.000	0.562	40.876	
	38.000	0.625	36.750			40.000	0.625	38.750			42.000	0.625	40.750	
	38.000	0.688	36.624			40.000	0.688	38.624			42.000	0.688	40.624	
	38.000	0.75	36.500			40.000	0.75	38.500			42.000	0.75	40.500	
	38.000	0.812	36.376			40.000	0.812	38.376			42.000	0.812	40.376	
	38.000	0.875	36.250			40.000	0.875	38.250			42.000	0.875	40.250	
	38.000	0.938	36.124			40.000	0.938	38.124			42.000	0.938	40.124	
	38.000	1	36.000			40.000	1	38.000			42.000	1	40.000	
	38.000	1.062	35.876			40.000	1.062	37.876			42.000	1.062	39.876	
	38.000	1.125	35.750			40.000	1.125	37.750			42.000	1.125	39.750	
	38.000	1.188	35.624			40.000	1.188	37.624			42.000	1.188	39.624	
	38.000	1.25	35.500			40.000	1.25	37.500			42.000	1.25	39.500	

Note: Dimensions are in inches.

Note: Bore schedules with wall thickness greater than .88 are in bold print, indicating different welding end contour.

BORE SCHEDULES



ASME B36.10M - 1996

NOMINAL WALL THICKNESS AND INSIDE DIAMETER														
Nominal Pipe Size	Outside Diameter	Wall thickness	Bore size	schedule	Nominal Pipe Size	Outside Diameter	Wall thickness	Bore size	schedule	Nominal Pipe Size	Outside Diameter	Wall thickness	Bore size	schedule
44	44.000	0.25	43.500		46	46.000	0.25	45.500		48	48.000	0.25	47.500	
	44.000	0.281	43.438			46.000	0.281	45.438			48.000	0.281	47.438	
	44.000	0.312	43.376			46.000	0.312	45.376			48.000	0.312	47.376	
	44.000	0.344	43.312			46.000	0.344	45.312			48.000	0.344	47.312	
	44.000	0.375	43.250	STD		46.000	0.375	45.250	STD		48.000	0.375	47.250	
	44.000	0.406	43.188			46.000	0.406	45.188			48.000	0.406	47.188	
	44.000	0.438	43.124			46.000	0.438	45.124			48.000	0.438	47.124	
	44.000	0.469	43.062			46.000	0.469	45.062			48.000	0.469	47.062	
	44.000	0.5	43.000	XH		46.000	0.5	45.000	XH		48.000	0.5	47.000	
	44.000	0.562	42.876			46.000	0.562	44.876			48.000	0.562	46.876	
	44.000	0.625	42.750			46.000	0.625	44.750			48.000	0.625	46.750	
	44.000	0.688	42.624			46.000	0.688	44.624			48.000	0.688	46.624	
	44.000	0.75	42.500			46.000	0.75	44.500			48.000	0.75	46.500	
	44.000	0.812	42.376			46.000	0.812	44.376			48.000	0.812	46.376	
	44.000	0.875	42.250			46.000	0.875	44.250			48.000	0.875	46.250	
	44.000	0.938	42.124			46.000	0.938	44.124			48.000	0.938	46.124	
	44.000	1	42.000			46.000	1	44.000			48.000	1	46.000	
	44.000	1.062	41.876			46.000	1.062	43.876			48.000	1.062	45.876	
	44.000	1.125	41.750			46.000	1.125	43.750			48.000	1.125	45.750	
	44.000	1.188	41.624			46.000	1.188	43.624			48.000	1.188	45.624	
	44.000	1.25	41.500			46.000	1.25	43.500			48.000	1.25	45.500	

Note: Dimensions are in inches.

Note: Bore schedules with wall thickness greater than .88 are in bold print, indicating different welding end contour.

BORE SCHEDULES



ASME B36.10M - 1996

NOMINAL WALL THICKNESS AND INSIDE DIAMETER														
Nominal Pipe Size	Outside Diameter	wall thickness	Bore size	schedule	Nominal Pipe Size	Outside Diameter	wall thickness	Bore size	schedule	Nominal Pipe Size	Outside Diameter	wall thickness	Bore size	schedule
52	52.000	0.25	51.500		56	56.000	0.25	55.500		60	60.000	0.25	59.500	
	52.000	0.281	51.438			56.000	0.281	55.438			60.000	0.281	59.438	
	52.000	0.312	51.376			56.000	0.312	55.376			60.000	0.312	59.376	
	52.000	0.344	51.312			56.000	0.344	55.312			60.000	0.344	59.312	
	52.000	0.375	51.250			56.000	0.375	55.250			60.000	0.375	59.250	
	52.000	0.406	51.188			56.000	0.406	55.188			60.000	0.406	59.188	
	52.000	0.438	51.124			56.000	0.438	55.124			60.000	0.438	59.124	
	52.000	0.469	51.062			56.000	0.469	55.062			60.000	0.469	59.062	
	52.000	0.5	51.000			56.000	0.5	55.000			60.000	0.5	59.000	
	52.000	0.562	50.876			56.000	0.562	54.876			60.000	0.562	58.876	
	52.000	0.625	50.750			56.000	0.625	54.750			60.000	0.625	58.750	
	52.000	0.688	50.624			56.000	0.688	54.624			60.000	0.688	58.624	
	52.000	0.75	50.500			56.000	0.75	54.500			60.000	0.75	58.500	
	52.000	0.812	50.376			56.000	0.812	54.376			60.000	0.812	58.376	
	52.000	0.875	50.250			56.000	0.875	54.250			60.000	0.875	58.250	
	52.000	0.938	50.124			56.000	0.938	54.124			60.000	0.938	58.124	
	52.000	1	50.000			56.000	1	54.000			60.000	1	58.000	
	52.000	1.062	49.876			56.000	1.062	53.876			60.000	1.062	57.876	
	52.000	1.125	49.750			56.000	1.125	53.750			60.000	1.125	57.750	
	52.000	1.188	49.624			56.000	1.188	53.624			60.000	1.188	57.624	
	52.000	1.25	49.500			56.000	1.25	53.500			60.000	1.25	57.500	

Note: Dimensions are in inches.

Note: Bore schedules with wall thickness greater than .88 are in bold print, indicating different welding end contour.